



For protection and for the security of all those spaces that require controlled access, BFT proposes strong retractable bollards which require the minimum maintenance. Thanks to their small aesthetic impact, they provide the ideal solution for places such as old city centres and zones of particular architectural merit.

SOLUTIONS FOR REGULATING PARKING AND PASSAGE

STOPPY



STOPPY SERIES

ELECTROMECHANICAL OPERATOR FOR RISING BOLLARD

132



• **A MODEL FOR EVERY NEED.**

→ Version with lights and alarm.

• **SMART TECHNOLOGY.**

→ Can be configured as follows for power failure: automatic descent or extracted position (with optional Stoppy BAT accessory); When there is no battery power, Stoppy returns flush to the ground automatically with slight pressure and without causing obstacles.

• **SAFE USE.**

→ Its reflective surface ensures visibility even at night.

CODE	DESCRIPTION	VOLTAGE	OPERATOR STROKE	Q.TY PER PALLETS
P970001 00002	STOPPY	230 V	500 mm	6
P970002 00002	STOPPY L	230 V	500 mm	6
P970007 00002	STOPPY LAR	230 V	500 mm	6
P970007 00004	STOPPY LAR INOX NEW²⁰⁰⁹	230 V	500 mm	6
P970001	STOPPY F	-	500 mm	6
P970045 00002	STOPPY H NEW²⁰⁰⁹	230 V	700 mm	1
P970045 00003	STOPPY H L NEW²⁰⁰⁹	230 V	700 mm	1
P970045 00004	STOPPY H LAR NEW²⁰⁰⁹	230 V	700 mm	1
P970045 00005	STOPPY H LAR INOX NEW²⁰⁰⁹	230 V	700 mm	1
P970045 00001	STOPPY H F NEW²⁰⁰⁹	-	700 mm	1

STOPPY L with warning lights

STOPPY LAR with theft prevention KIT and warning lights

STOPPY F fixed rising bollards

TECHNICAL FEATURES

FEATURES OF THE RANGE

SPECIFIC FEATURES

		STOOPY	STOPPY H
CONTROL PANEL	PERSEO N		
REVERSIBLE/IRREVERSIBLE OPERATOR	reversible		
POWER SUPPLY	230 V~ ± 10%, 50 Hz single-phase		
ABSORBED POWER	270 W		
THERMAL PROTECTION	integrated		
OPENING OR CLOSING TIME		6 s + slowdown	9 s + slowdown
IMPACT REACTION		8000 J	8000 J
MAX TORQUE	1000 Nm		
TYPE OF LOCK	electric brake		
TYPE OF LIMIT SWITCHES	magnetic		
MANUAL RELEASE	reversible in case of black-out		
OPERATING CYCLE	very intensive use		
ENVIRONMENTAL CONDITIONS	from -25°C to +60°C (STOPPY L/HL: from -15°C to +60°C)		
DEGREE OF PROTECTION	IP67		
OPERATOR WEIGHT		90 kg	110 kg



DIMENSIONS (mm)

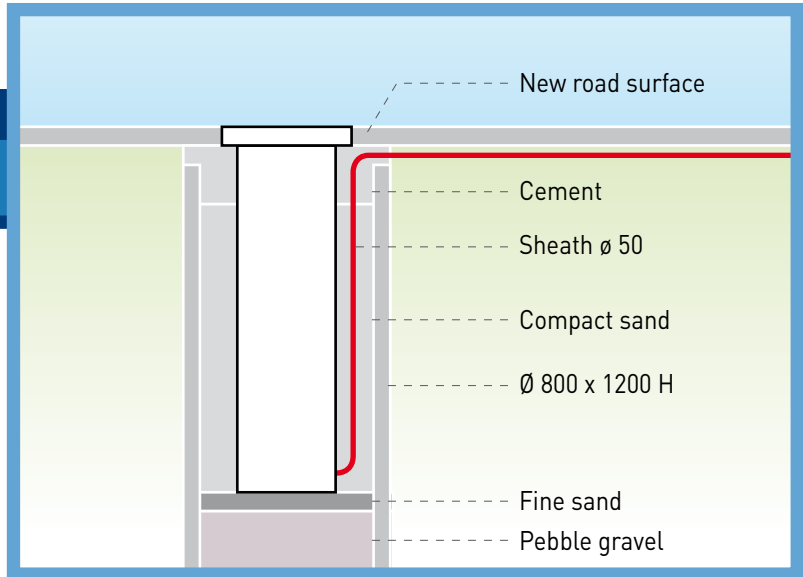
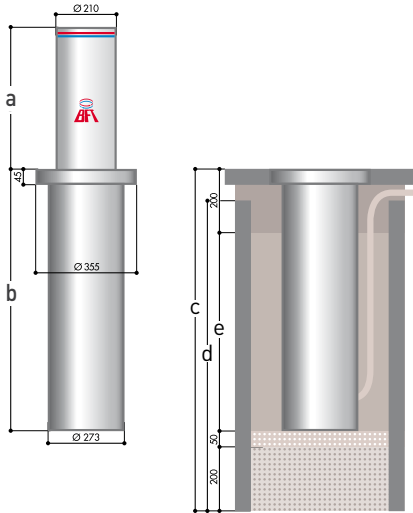

mm	STOPPY	STOPPY H
a	500	700
b	915	1175
c	1100	1350
d	1000	1250
e	650	1000

ACCESSORIES

NEW 2009



D113653 00008
PERSEO N
See page 141



D113653 00002
PERSEO
See page 142
Not suitable for STOPPY H motors
Available while stock last.



P975001 - STOPPY BAT
Back-up battery kit that allows the bollard to stay up even in the event of power failure.



D113705
ACOUSTIC DETECTOR
Adjustable acoustic siren detector.



P111001 00003
RMM 2
Two-channel metal detectors. 230V~



D110926 00001 - SPIRA 2X1
Magnetic loop 2x1 m.

NEW 2009



P800037 - TBA
Totem bottom element for STOPPY



NEW 2009
P800038 - TSU
Totem top element for STOPPY



NEW 2009
P800039 - TL
Totem lights for STOPPY.

NEW 2009

P800040 - TPF
Totem anchor plate for STOPPY.

NEW 2009

P800034 - CABLE STOPPY
Power cable for STOPPY. 50m reel.

NEW 2009

***P800041**
Additional charge for STOPPY with total cable length of 25 m.

NEW 2009

***P800042**
Additional charge for STOPPY with total cable length of 50 m.

*By ordering items P800041 and P800042, you can receive STOPPY operators already fitted with a cable measuring a total length of 25 or 50 metres. These items must therefore be ordered in addition to that of a bollard. For example, to receive a STOPPY L with a 25 metre cable, you will need to order items P970002 00002 and P800041.